

First in Quality. Built to **Last**.

AUTOMATIC BUNDLER PROFESSIONAL SERIES

MODELS

SB35A, SB50A, SB70A, SB80A

BUILT RIGHT...PRICED RIGHT

Proven reliable over and over again, Streamline Solutions' automatic bundler provides you with all the quality features found in much higher priced machines. They are designed and built to give you all the features needed for positive sealing of polyethylene film.

RUGGED DESIGN

Streamline Solutions' automatic bundler's are expertly welded on 1/4" cold rolled steel frames and designed to handle the day to day abuse of even the most demanding bundling applications. Each bundler utilizes two rolls of single wound film mounted on the same side of the machine and an upper and lower power film unwind for ease of use. See for yourself why Streamline Solutions has been a leader in the shrink packaging industry for over 25 years.

STANDARD FEATURES

- Designed to seal polyethylene films
- 35", 50", 70", and 80" wide hot knife seal system
- 22" adjustable product pass through height
- Upper and lower powered film unwind for smooth feed of film
- Film loading from left or right side
- Color PLC touchscreen operation for easy adjustments
- Self tracking conveyor belt and product indexing

RELIABLE AUTOMATIC BUNDLING

Streamline Solutions' automatic bundler's offers the reliability needed to provide a "bull's-eye closure" on trays, individual, or multi-packed products.

STANDARD FEATURES (cont.)

- Flexibility for fully automatic or single product operation
- 4' conveyor length standard
- 78" max film width
- 12" max film OD
- All-welded main frame from 1/4" cold rolled steel
- Bases supplied with locking casters for easy transport
- Leveling legs to provide sturdy base
- Durable custom two-part epoxy finish resists scratching
- 220v standard; Optional 480V
- Made in the USA
- Easy to use design requires minimal training, maintenance, and trouble free operation

OPTIONS

- Additional 4" seal head height
- Additional 2" seal bar length extension
- Optional product guides Interlocked guard doors
- Product hold down
- Single belt option for infeed and exit conveyor
- Extended Infeed or Exit conveyor length
- Left or right angle infeed conveyors available Manual infeed available
- Dual film rack or pull out film rack
- Low film indicator
- Additional E-Stop button
- Optional password protection UL approved electronics and control box
- Left hand machines available
- Custom sizes and configurations available upon request

**Ask Us About Custom Equipment*





1. **Color Touchscreen Panel**
Color PLC touchscreen can be password protected if needed
2. **Control Panel**
Easy to use control panel lets users adjust dwell time and temperature settings for their specific application
3. **Rugged Exit Conveyor**
Exit conveyor transfers the package into a recommended Eastey shrink bundling tunnel to produce a very tight and secure package
4. **Hot Knife**
35", 50", 70" & 80", hot knife seal system ensures a clean, positive, and even seal every time

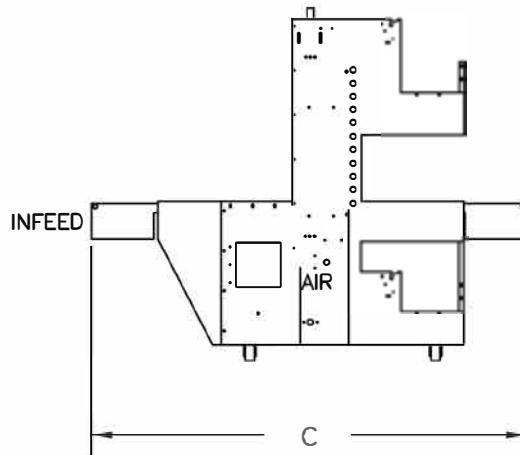
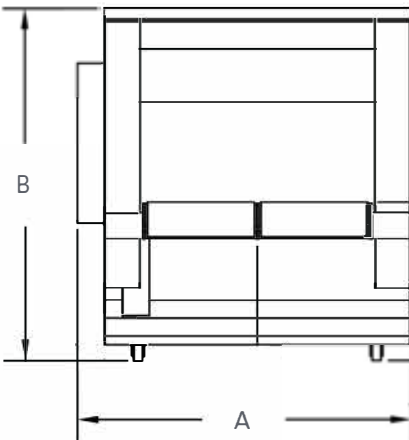

MODEL NUMBER	MACHINE DIMENSIONS			SEAL DIMENSIONS		CONVEYOR DIMENSIONS		STANDARD POWER			WEIGHT	SHP WT.
	WIDTH (A)	HEIGHT (B)	LENGTH (C)	WIDTH	HEIGHT	WIDTH	LENGTH	VOLTS	AMPS	PHASE		
SB35A	61"	79"	98"	35"	22"	37"	98"	220	10	1	2300 lbs	2500 lbs
	154 cm	200 cm	248 cm	88 cm	55 cm	93 cm	248 cm				1043 kg	1133 kg
SB50A	76"	79"	98"	50"	22"	52"	98"	220	15	1	2800 lbs	3000 lbs
	72 cm	200 cm	248 cm	127 cm	55 cm	132 cm	248 cm				1270 kg	1360 kg
SB70A	96"	79"	98"	70"	20"	72"	98"	220	20	1	3300 lbs	3500 lbs
	243 cm	200 cm	248 cm	177 cm	51 cm	182 cm	248 cm				1496 kg	1587 kg
SB80A	108.5"	79"	98"	80"	22"	78"	98"	220	30	1	3700 lbs	3900 lbs
	276 cm	200 cm	248 cm	203 cm	55 cm	198 cm	248 cm				1678 kg	1769 kg



 **First in Quality. Built to Last.**



BUNDLING TUNNELS PROFESSIONAL SERIES

MODELS

STB2416, STB2420, STB3616, STB3620, STB4816, STB4820,
STB5616, STB5620, STB7016, STB7020

BUILT RIGHT...PRICED RIGHT

Proven reliable over and over again, STREAMLINE SOLUTIONS bundling tunnels provide you with all the quality features found in much higher priced machines. They are designed and built to give you all the features needed for positive shrinking of polyethylene film.

RUGGED DESIGN

STREAMLINE SOLUTIONS' top of the line bundling tunnels are expertly welded on 12 gauge steel frames and designed to handle the day to day abuse of most bundling applications. Each tunnel utilizes four-directional variable air flow to provide a positive shrink. See for yourself why STREAMLINE SOLUTIONS has been a leader in the shrink packaging industry for over 25 years.

STANDARD FEATURES

- Designed to shrink polyethylene film.
- All-welded main frame from 12 gauge steel
- 78" chamber length to ensure proper shrinking of film
- High temperature belting resists wear

RELIABLE SHRINK PERFORMANCE

STREAMLINE SOLUTIONS' STB Series bundling tunnels offer the reliability needed to provide positive shrinking and are designed specifically for bundling applications.

STANDARD FEATURES (cont.)

- Sealed bearings (not bushings) on drive and idler shafts
- Adjustable digital solid state temperature control for a variety of films
- Four-directional air flow provides positive shrinking
- Variable air flow for a variety of products and applications
- Large ducting creates more air volume inside tunnel
- Airflow extended to the end of the chamber sides
- 4' product cooling conveyor on exit end
- Exit cooling fans accelerate shrinking
- Delayed cool down and over temperature protection
- Fold down electrical control panel for easy maintenance
- Heavy duty casters for transportation within plant
- Leveling legs provide sturdy base once in place
- Custom two part epoxy finish resists scratching
- Available in 220v - single or 3-phase
- Easy to use design requires minimal training, maintenance, and trouble free operation
- Made in the USA

OPTIONS

- Wipe down rollers - standard or pneumatic
- Raised hood - additional 4" or 8" product height
- UL approved electronics and control box
- Left hand machines available
- Custom sizes and configurations available upon request

**Ask Us About Custom Equipment*





1. **Reliable Shrink Performance**

Proven Streamline Solutions tunnels provide positive shrinking of polyolefin, polyethylene and PVC films

2. **High Temperature Belting**

High temperature belting resists wear and is designed specifically for polyethylene films

3. **Control Panel**

Easy to use control panel lets users adjust for their specific application

4. **Variable Air Flow**

Four directional air flow provides positive shrinking for a variety of products and applications

MODEL NUMBER	MACHINE DIMENSIONS			CHAMBER DIMENSIONS			CONVEYOR LENGTH	STANDARD POWER			WEIGHT	SHP WT.
	WIDTH (A)	HEIGHT (B)	LENGTH (C)	WIDTH	HEIGHT	LENGTH		VOLTS	AMPS	PHASE		
STB2416	43"	56"- 72"	149"	24"	16" - 20"	78"	147"	480	30	3	1900 lbs	2000 lbs
	109 cm	142-182 cm	378 cm	60 cm	20 cm	76 cm	373 cm				861 kg	908 kg
STB2420	43"	56"- 72"	149"	24"	16" - 20"	78"	147"	480	30	3	1900 lbs	2000 lbs
	109 cm	142-182 cm	378 cm	60 cm	40 - 50 cm	198 cm	373 cm				861 kg	908 kg
STB3616	55"	56"- 72"	149"	36"	16" - 20"	78"	147"	480	60	3	2200 lbs	2300 lbs
	139 cm	142-182 cm	378 cm	91 cm	40 - 50 cm	198 cm	373 cm				997 kg	1043 kg
STB3620	55"	56"- 72"	149"	36"	16" - 20"	78"	147"	480	60	3	2200 lbs	2300 lbs
	139 cm	142-182 cm	378 cm	91 cm	40 - 50 cm	198 cm	373 cm				997 kg	1043 kg
STB4816	67"	56"- 72"	149"	48"	16" - 20"	78"	147"	480	100-120	3	2600 lbs	2700 lbs
	170 cm	142-182 cm	378 cm	121 cm	40 - 50 cm	198 cm	373 cm				1179 kg	1224 kg
STB4820	67"	56"- 72"	149"	48"	16" - 20"	78"	147"	480	100-120	3	2600 lbs	2700 lbs
	170 cm	142-182 cm	378 cm	121 cm	40 - 50 cm	198 cm	373 cm				1179 kg	1224 kg
STB5616	75"	56"- 72"	149"	56"	16" - 20"	78"	147"	480	100-120	3	2900 lbs	3000 lbs
	190 cm	142-182 cm	378 cm	142 cm	40 - 50 cm	198 cm	373 cm				1315 kg	1360 kg
STB5620	75"	56"- 72"	149"	56"	16" - 20"	78"	147"	480	100-120	3	2900 lbs	3000 lbs
	190 cm	142-182 cm	125 cm	142 cm	40 - 50 cm	198 cm	373 cm				1315 kg	1360 kg
STB7016	89"	56"- 72"	149"	70"	16" - 20"	78"	147"	480	100-120	3	3200 lbs	3300 lbs
	226 cm	142-182 cm	155 cm	177 cm	40 - 50 cm	198 cm	373 cm				1451 kg	1496 kg
STB7020	89"	56"- 72"	149"	70"	16" - 20"	78"	147"	480	100-120	3	3200 lbs	3300 lbs
	226 cm	142-182 cm	124 cm	177 cm	40 - 50 cm	198 cm	373 cm				1451 kg	1496 kg



STREAMLINE SOLUTIONS™



REVISIONS						
REV	ECO #	DESCRIPTION	DRAFT	CHRR	APPR	DATE
1	-1/-	INITIAL RELEASE	TMS	TMS	TMS	2/17/20

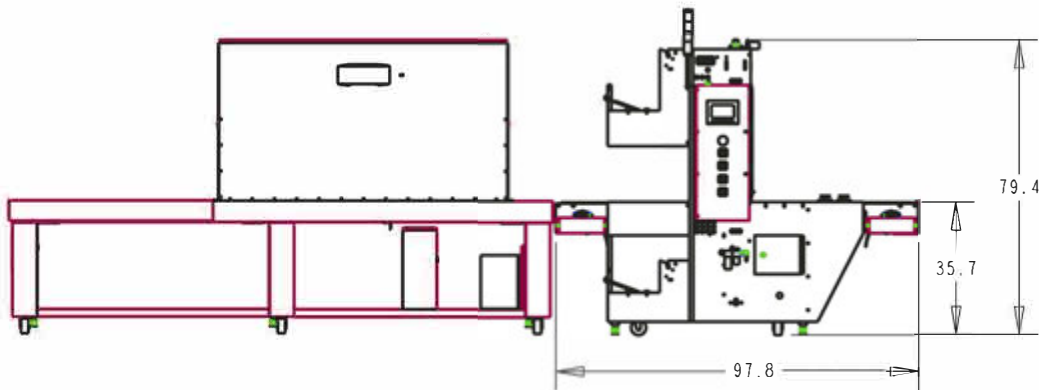
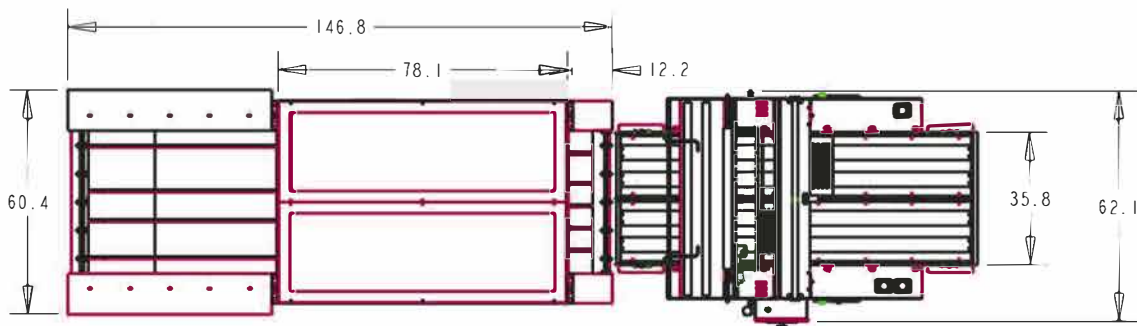

UNLESS OTHERWISE SPECIFIED .XX = .01 .XXX = .005 ANGLE = .5		MATERIAL N/A	STREAMLINE SOLUTIONS P.O. Box 56073 Orlando, FL 32856 407-244-7700	
THIRD ANGLE PROJECTION		FINISH N/A	TITLE SB35-AV1 WRAPPER AND STB3620-PBV6 TUNNEL	
DRAWN BY TMS 2/17/20		SCALE 0.025	SIZE A	MODEL NUMBER SB35-AV1
THIS DOCUMENT AND THE DATA DISCLOSED HEREIN OR HEREWITH IS NOT TO BE REPRODUCED, USED OR OTHERWISE DISCLOSED IN WHOLE OR IN PART TO ANYONE WITHOUT THE WRITTEN CONSENT OF STREAMLINE SOLUTIONS.		MODIFIED BY TMS 2/17/20	DRAWING NUMBER 3 SB35-AV1_STB3620	REV 1 SHEET 1 OF 1

Pro/ENGINEER Document DXF FILE AVAILABLE UPON REQUEST