



**First** in Quality. Built to Last.



## STREAMLINE SOLUTIONS

### SIDE BELT & TOP BELT CASE TAPER

#### MEET YOUR CASE TAPING NEEDS

Streamline Solutions' SB/TB Case Taper offers the quality that you have come to rely on from Streamline Solutions. The system's unique and simple design has proven to be one of the most reliable case tapers on the market today, keeping production and maintenance efforts to a minimum and providing fast and efficient alternatives to hand taping.

#### WIDE STANDARD CASE RANGE

SB/TB offers fast and easy case changes and flexibility for boxes 4.75" in length and greater. Adjustments can be made on the fly with easy hand tighten knobs and cranks. SB/TB utilizes Easy-Taper Quick-Load top and bottom tape cartridges and will seal boxes as large as 27.5" wide and as tall as 27.5", offering the user more options for their case taping operation.

#### MAXIMUM STABILITY

Four drive belts work in unison to effectively move your cases through for a strong and consistent seal. SB/TB utilizes a dual mast with twin lead screws for greater tape head stability, and an adjustable side belt drive to center each case. The unit also features top compression rollers to stabilize the case and push the top flaps together, making it a great solution for over-filled and over-sized cases.

## DESIGNED FOR EXTRA LARGE CASES

The SB/TB's top and side belts are great for over-sized, heavy weight cases that are too large for most case sealing equipment.

#### INDUSTRIAL STRENGTH OPERATION

Dual 1/4 HP side drive motors with single top drive motor, aggressive industrial strength drive belts, and roller tables make SB/TB a workhorse that will stand up to your toughest challenges. Each case taping machine is made from 12 gauge steel that will withstand even the most rugged applications. A powder coated exterior protects the machine from abusive conditions and ensures years of use. Best of all, the SB/TB is CE certified, so users can be confident it will consistently provide reliable, high quality case sealing.

#### INCREASE YOUR ROI

Top and bottom tape heads lift out for easy threading and accept 2" wide pressure-sensitive tape as a standard, or can be ordered with 3" tape heads. The use of Eastey's SB/TB case taping machine can be learned in minutes, avoiding breaks in production and downtime, saving your company money and increasing your ROI.

#### THE RIGHT SOLUTION

Rugged design. Proven reliability. Simple operation. Your benefits go on and on. When it comes to industrial operation, rely on Streamline Solutions to provide the right solution for your case sealing needs.



STREAMLINE SOLUTIONS™

[www.streamlinesolutionsusa.com](http://www.streamlinesolutionsusa.com)

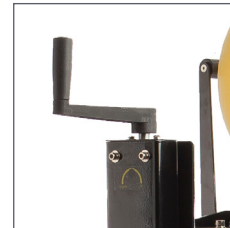
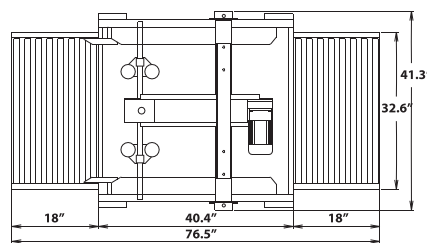
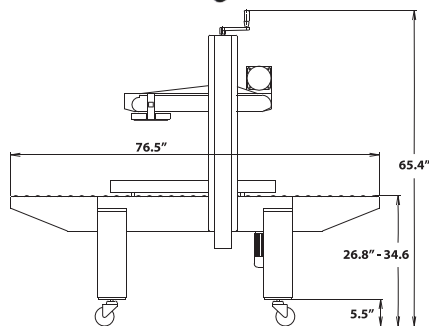

1. Designed for over-sized, heavyweight cases that are too large for most case sealing equipment
2. Four belts work in unison to efficiently move cases through the taper for a strong and consistent seal
3. Easy-to-use hand crank allows for quick product height adjustments
4. Top and bottom tape heads are identical and can be removed without tools

### SB/TB-2 FEATURES

- Plug-in and go operation
- Fast and easy box size changes
- Industrial strength side belts
- Interchangeable top and bottom tape cartridges
- Emergency stop button
- Adjustable leg extensions
- Casters included for transportation within plant
- Front and rear pack tables included to allow for case packing
- Top squeezers push top flaps together on overfilled cases
- Powder coated 12 gauge steel
- Low maintenance, no air required

### SB/TB-2 TAPING SPECIFICATIONS

Sealer Type	Side and top belt case sealer
Machinery Makeup	Industrial strength 12 gauge steel, powdered coated for durability
Belt Speed	75 fpm
Tape Speed	30 cases per min., depending on box size and operator efficiency
Height Adjustment	Standard adjustable legs for 26.8" to 34.6" conveyor heights

BOX SPECIFICATIONS	Length	Width	Depth
Minimum Box Size	4.75"	7.0"	4.7"
Maximum Box Size	Infinite	27.5"	27.5"
Tape Size	2" wide pressure sensitive tape, up to 15" diameter rolls, optional 3" wide tape		
Tape Cartridge	Proven design requires no lubrication, designed for simple tape threading, removable for maintenance and interchangeable with top or bottom cartridges		
Drive Motor	Three (3) 1/4 HP drive motors		
Electrical Requirements	110 VAC, 60Hz, 4.0A		
Agency Approvals	CE Certification		

### SB/TB-2 OPTIONAL ACCESSORIES

3" Tape Head	Accepts 3" wide tape rolls
--------------	----------------------------



(866)244-7700  
 info@streamlinesolutionsusa.com  
 P.O. Box 560775, Orlando, FL 32856  
[www.streamlinesolutionsusa.com](http://www.streamlinesolutionsusa.com)